

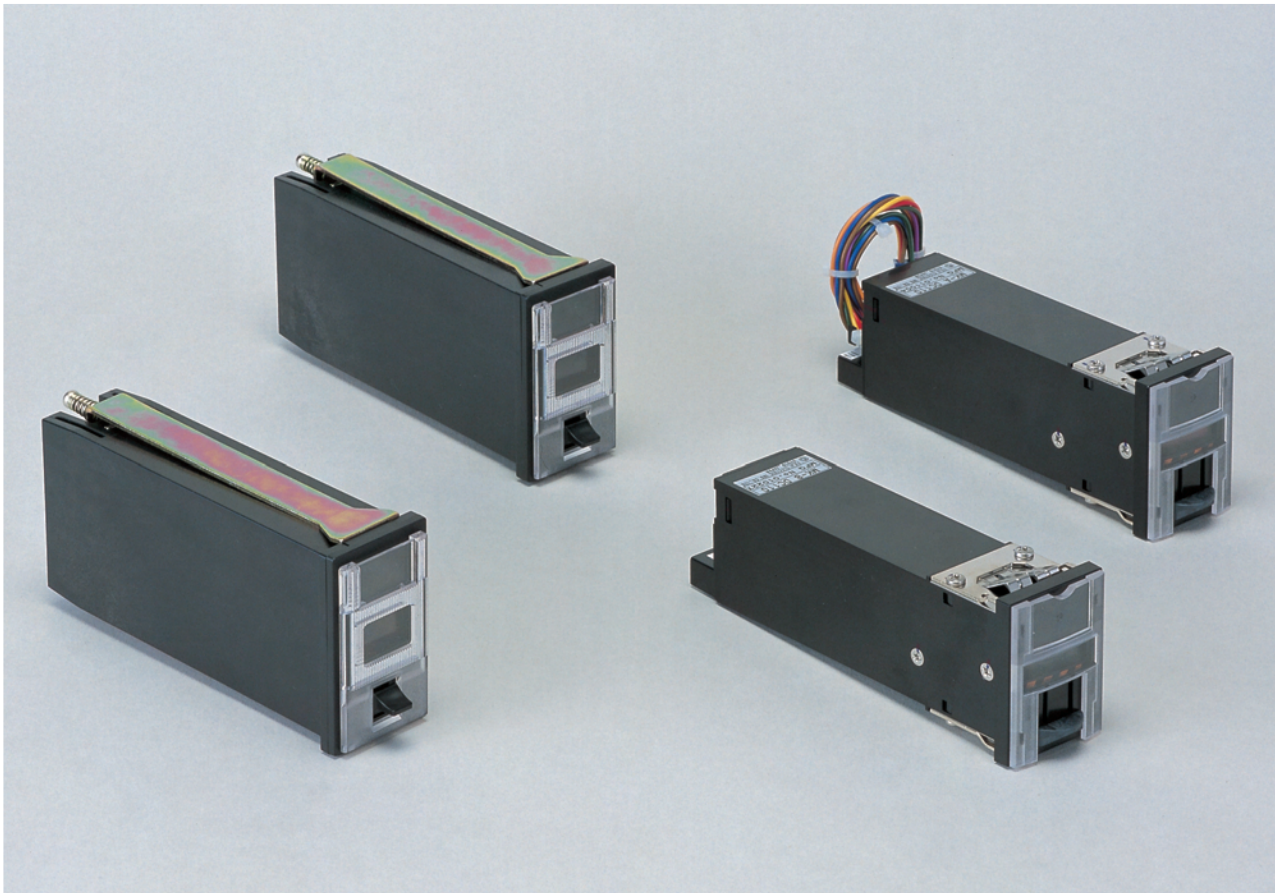

# TARGET TYPE FAULT INDICATORS



## FEATURES

- The built-in switching contacts is applicable for the output from 4 circuits with different functions. The use of this indicator allows saving the auxiliary relays.
- The versions for voltage and current are so designed as to prevent wrong insertion.
- The display element is a plug-in type facilitating maintenance and checks (or replacement).
- A no-voltage one-shot pulse contact may be incorporated.
- A variety of models with different combinations of output contacts are available.
- The indicator is housed in a plastic case and can be mounted either independently or in an assembly.

## SPECIFICATIONS (RATINGS, PERFORMANCE)

Specification	Type	TK	MK
Rated insulation voltage		250V	
Operating temperature range		-22 to 55°C	
Operating humidity range		45 to 85%	
Storing temperature		-40 to 70°C	
Shape		Embedded in switchboard, with 1 element	
Mounting panel		1 to 3.2mm	
Inclination of applicable panel		30 degrees max. from vertical plane	
Surface cover color		JIS (Munsell color) code: N1.5 7.5BG4/1.5 (N1.5 only for MK type)	



# TARGET TYPE FAULT INDICATORS

## ORDERING METHOD

Select from the following product coding.

## PRODUCT CODING

### TK type

# TKL 121-DC11-B

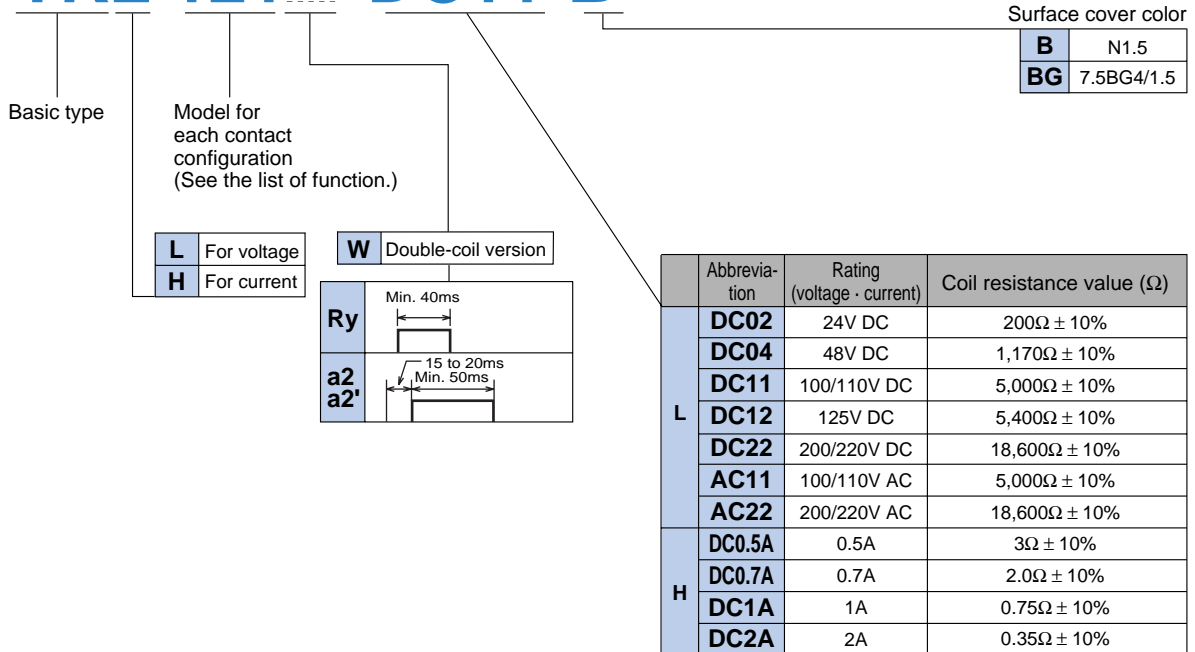

### MK type

# MK-A DC110

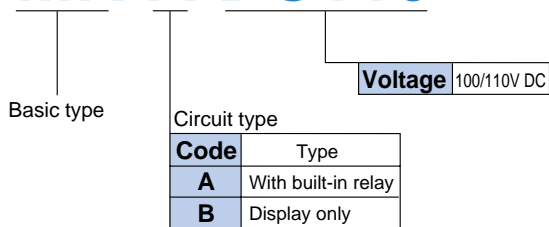



# TK TYPE

## TK TYPE

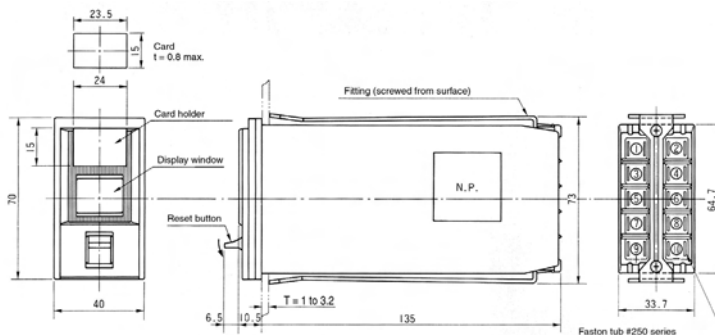

● Mounting hole size

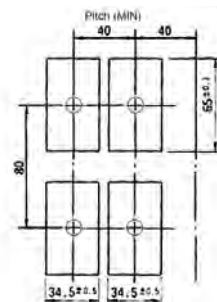

- Operation ... Dual modes: single-display manual resetting and multi-display automatic resetting
- Specification of element

Items	Type	For voltage	For current
Rating		Continuous at rated value	
Overload tolerance		Coil temperature rise of 55°C max. in the maximum operating range (1.3 times the rating for 3 hours)	30S at 500%
Minimum operating value		70% max. of rating	80% max. of rating
Contact current capacity		3A 110V DC	
Contact breaking capacity		R load: 0.4A (110V DC) 0.2A (220V DC) L load: 0.1A (110V DC) 0.03A (220V DC) L/R = 12 ms	
Operating time (rated voltage and current)		a1: 60±15 ms a2: 40±10 ms a3: 90±10 ms	a1: 50±15 ms a2: 20±10 ms a3: 80±10 ms
Pulse contact time		50 to 70 ms	
Display panel		In normal use: N1.5 At failure: 2.5YR6/13 When failure persists: N1.5 and 2.5YR6/13 stripes	In normal use: N1.5 At failure: 2.5YR6/13
Insulation resistance		Min. 50MW (500V DC)	
Withstand voltage		Whole terminals and contact points: 2,000V AC/1 min. Between electric circuit and contact: 2,000V AC/1 min. Between contact circuits: 2,000V AC/1 min. Between open contacts: 1,000V AC/1 min.	
Lightning impulse		Between open contacts: 3,000V (1.2/50µs) Between live parts and live part to assembly mounting panel: 4,000V (1.2/50µs)	
Durability		10,000 times min. each for electrical and mechanical durability	
Vibration resistance		Frequency: 16.7 Hz Double amplitude: 4 mm Back-and-forth/horizontal/vertical for 10 minutes	
Shock resistance		Shock resistance: 30G Back-and-forth/horizontal: 2 times each	



## CONTACT CONFIGURATION DIAGRAM

(1)TK:100

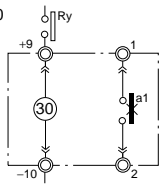

(9)TK:010

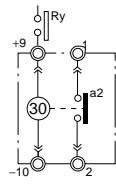

(17)TK:12B0

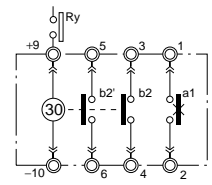

(2)TK:200

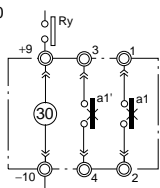

(10)TK:011

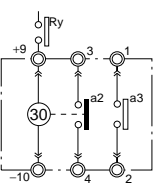

(18)TK:12B1

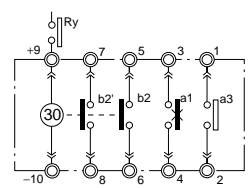

(3)TK:110

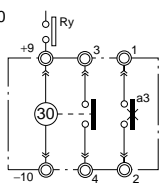

(11)TK:021

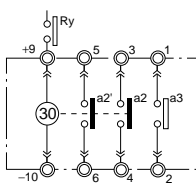

(19)TK:1AB1

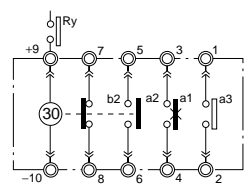

(4)TK:111

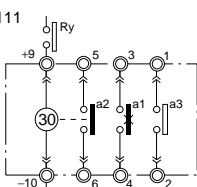

(12)TK:020

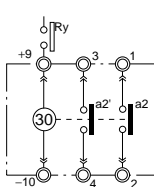

(20)TK:0AB0

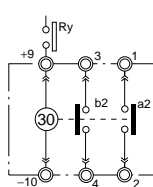

(5)TK:000

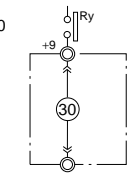

(13)TK:001

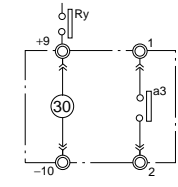

(21)TK:AB00

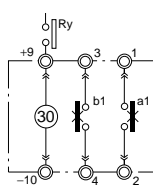

(6)TK:101

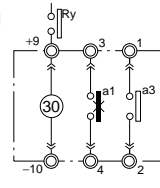

(14)TK:030

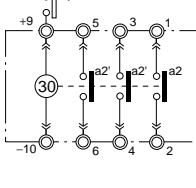

(22)TK:02C0

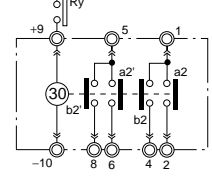

(7)TK:120

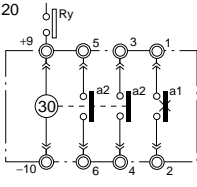

(15)TK:210

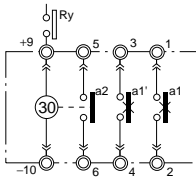

(23)TK:2C00

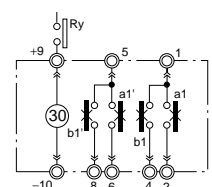

(8)TK:121

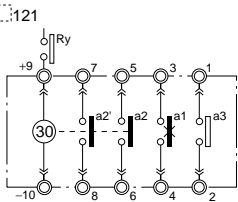

(16)TK:1AB0

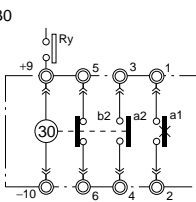

## LIST OF FUNCTIONS

No.	Model for each contact configuration	Input rating		Output contact			Reference *Standard { DC11 DC1A
		Voltage element (TKL)	Current element (TKH) (TKH...W)	Interlocked with display panel Manual resetting contact a1 ○ b1 ○	Interlocked with coil Automatic resetting contact a2 ○ b2 ○	Interlocked with display panel One-shot pulse contact a2 ○ b2 ○	
1	TK □ 100	○	○	1a	—	—	*
2	TK □ 200	○	○	2a	—	—	*
3	TK □ 110	○	○	1a	1a	—	
4	TK □ 111	○	○	1a	1a	1a	
5	TK □ 000	○	○	—	—	—	
6	TK □ 101	○	○	1a	—	1a	
7	TK □ 120	○	○	1a	2a	—	*
8	TK □ 121	○	○	1a	2a	1a	
9	TK □ 010	○	○	—	1a	—	
10	TK □ 011	○	○	—	1a	1a	
11	TK □ 021	○	○	—	2a	1a	
12	TK □ 020	○	○	—	2a	—	*
13	TK □ 001	○	○	—	—	1a	
14	TK □ 030	○	○	—	3a	—	
15	TK □ 210	○	○	2a	1a	—	
16	TK □ 1AB0	○	○	1a	1a1b	—	
17	TK □ 12B0	○	○	1a	2b	—	
18	TK □ 12B1	○	○	1a	2b	1a	
19	TK □ 1AB1	○	○	1a	1a1b	1a	
20	TK □ 0AB0	○	○	—	1a1b	—	
21	TK □ AB00	○	○	1a1b	—	—	
22	TK □ 02C0	○	○	—	2c	—	
23	TK □ 2C00	○	○	2c	—	—	

1. For the above □, specify L for voltage or H for current.
2. Contact configurations other than the above ones are also available. Contact the person in charge.



# TK TYPE

## DRAWING THE INTERNAL ELEMENT

## ACCESSORIES

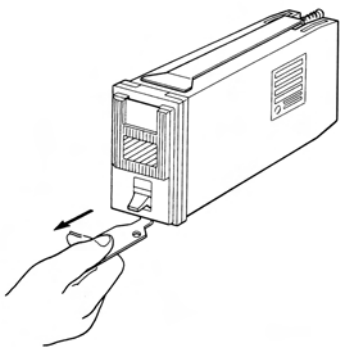

Removing the cover

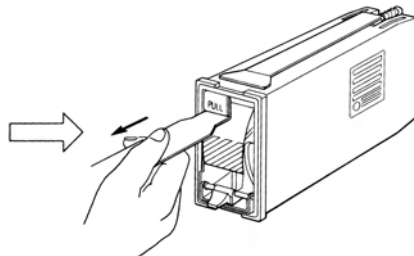

Drawing the element

TK remover

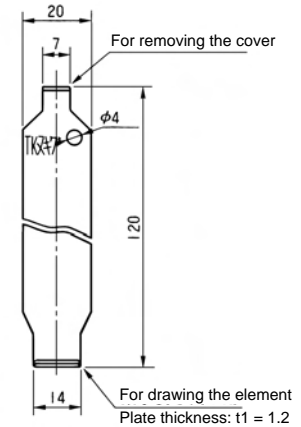

## DESCRIPTION OF OPERATION

- When a operating coil is excited by a signal from the relay or other devices, the indication plate drops and the indication wicket changes the indication from normal black to orange (2.5YR6/13)
- Next, when the reset lever is pressed down, the indication plate is restored to its original position. If the fault is momentary and no input is now present, the normal black indication is restored. However, if the fault continues, an orange (2.5YR6/13)-and-black (N1.5) striped pattern appears to show the continuation of the fault because of the presence of input to the coil. When the fault is removed, the normal black indication is restored automatically
- Up to four contact circuits can be incorporated, as following diagram.  
Up to two manual-reset contact circuits linked with the indication plate, up to three auto-reset contact circuits linked with coils, and up to two one-shot pulse contact circuits linked with the indication plate can be incorporated in a unit. Contacts a or b are provided for each circuit.
- The one-shot pulse contact generates pulses only at the initial operational stage (50~70ms).

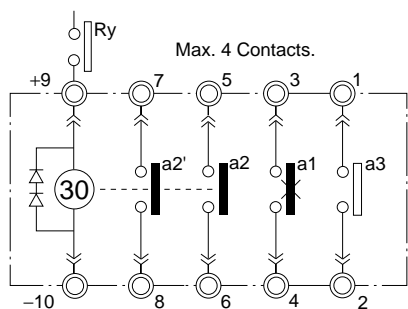

\*1: All the coils for voltage are added a counter induced-voltage absorption device.

Failure detection contact		Ry			
Display panel	Black				
	Orange				
	Pattern of stripes				
Contact	Interlocked with display panel (manual)	a1			
	Interlocked with coil (automatic)	a2			
		a2'			
	One-shot pulse	a3			
Recovery operation					





TARGET TYPE FAULT INDICATORS

# MK TYPE

## MK-A

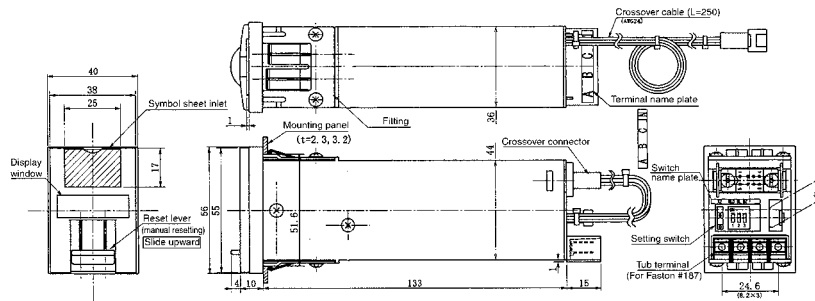
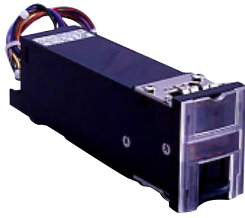

## MK-B

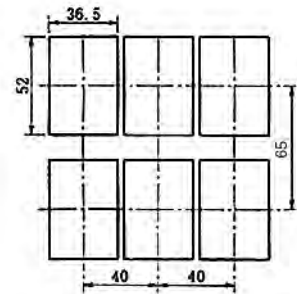
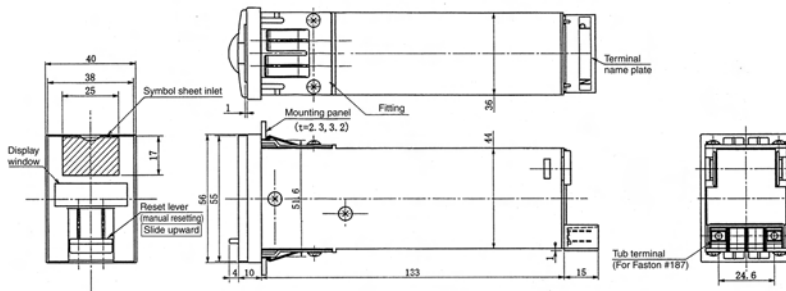

## TIME CHART

### MK-A

[At instantaneous failure]

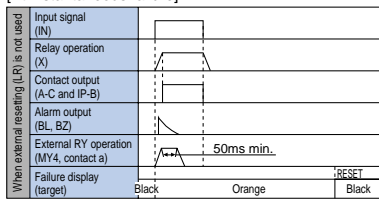

[At continuous failure]

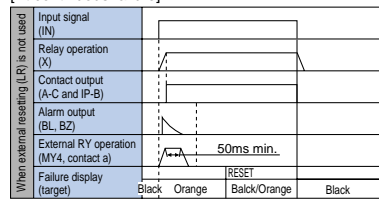

[When external resetting (LR) is not used]

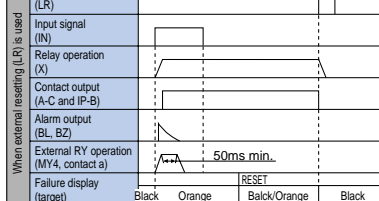

[When external resetting (LR) is used]

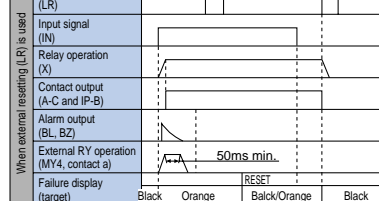

Failure (target)/display	
Black	
Orange	
Black/Orange	

### MK-B

● RESET: The target is manually reset.

[At instantaneous failure]

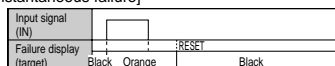

Failure (target)/display	
Black	
Orange	
Black/Orange	

[At continuous failure]

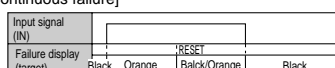



# MK TYPE

## CIRCUIT DIAGRAM

### MK-A

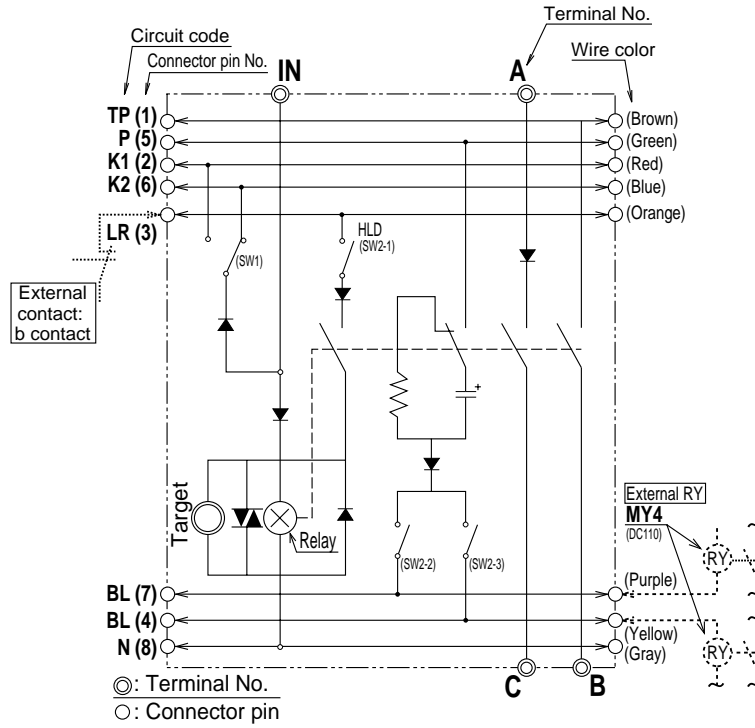

### MK-B

