

GENERALITY

The device of control temperatures CTT8 is used in the control of electric machine, transformer, motor, etc. where it's possible to control the temperature level signalling the critical temperature condition or to disable the machine under control. For example for the control the temperature of supplying transformer, where it's possible to control the temperatures of three coils of phase and the nucleus, using the tripped output (TRIP) to cut off the load and eventually the functions of ventilation control.

Another important function is the presence of one port of serial communication RS485, that allows the connection to system of acquisition (PC, PLC, scada, etc.) of the measure data, control and programming of the device. The MODBUS-RTU is the protocol used, it's documented in a specific manual.

A software for Windows environment is available for a management of the devices with complete function of control, storing data, recording alarm, etc. It's available a analogue output settable 0-20 or 4-20 mA with end-scale 200°C to join to one of channel or to the higher of the 4 temperature channels.



INTRODUCTION

The device type CTT8 allows the control and the visualization of temperature read with probe type RTD PT100 (). For each channel of measure are available two levels of alarm (alarm-tripped) that active the commutation of the relative output relay for signalling at distance or to disable the machine under control. On front of the instrument on a double display at 3 digit, it's possible the visualization of the temperatures, the visualization of the status of the alarm of the measure channels and 5 button for the programming. The instrument is completed by the functions of ventilation control, storing maximum values and storing of the tripped.

ACCESSORIES AND OPTION

accessories: transparent cover of frontal protection

options: serial output RS485
analogical output 0-20mA / 4-20mA user selectable

INSTALLATION

Foreward.

Read carefully the present manual before to install and use the device.

The device described in this manual must be installed and used by personal opportunely learned.

Security.

Before to proceed at the installation it's necessary verify if the device is intact and it haven't damages caused by transport. The power supply must be compatible with the tool range. The instrument installation must be done in total absence of voltage and observing the security norm in force. All operation of maintenance and reparation executed by not authorized person are forbidden. If during of functioning the device loose the security, it's necessary to put it out of service and to be sure that this device will not use unintentionally.

The use can be considered insecure when the instrument: - don't function regularly / - have damage clearly visible / - have damage caused of transport / - is stored in bad condition

CONNECTION OF THE THERMOMETER SENSORS

For the connection of the thermometer sensor RTD Pt100 it's necessary to follow the indication of the wiring diagram of this manual: pay attention not to invert the position between the conductors with red insulator and the conductor with white insulator. The probes type PT100 with 3 wires use a third wire to compensate the resistance of the conductors (max 20 ohm). If the sensor has 2 wires (normally white and red) it's necessary to short-circuit the terminals with the red wires (1-2, 4-5, 7-8, 10-11, 13-14, 16-17, 19-20, 22-23).

To reduce the external noises it's necessary to use the following indication for the wires of measure of the Pt100:

- to use probes with shielded wire connected at earth and wires twisted
- to separate the wires of the probes from wires of power
- to use wires with section higher than 0,5 mm²
- to use wires with conductor with tin or silver-plated

OUTPUT RELAYS

For the connection of the output contacts of relays it's necessary to follow the indication in the diagram.

The ALARM and TRIP relays commute when the threshold set are to get over. The FAULT relay is normally energized and it commute in presence of an anomaly on the Pt100 or on device. During the normally functioning of the device the contact 38-39 will be open while the 39-40 will be closed. The FAN relay is used to control the fun of cooler, in function of the threshold set of switch on and switch off.

WIRING CONNECTION

Pt 100

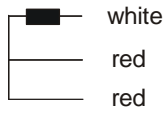

* Auxiliary power supply
U aux:
25 - 27: 24 ÷ 230V ca/cc
or
25 - 26: 115 Vca
25 - 27: 230 Vca
25 - 28: 400 Vca

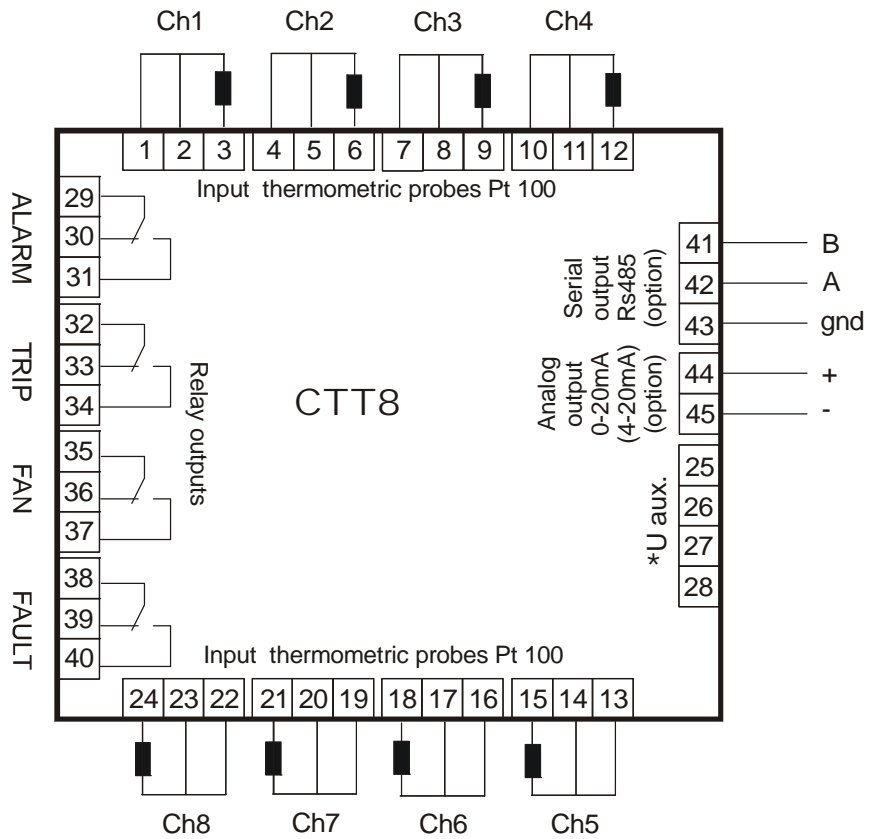

view rear panel
of the instrument with terminals
for the connections

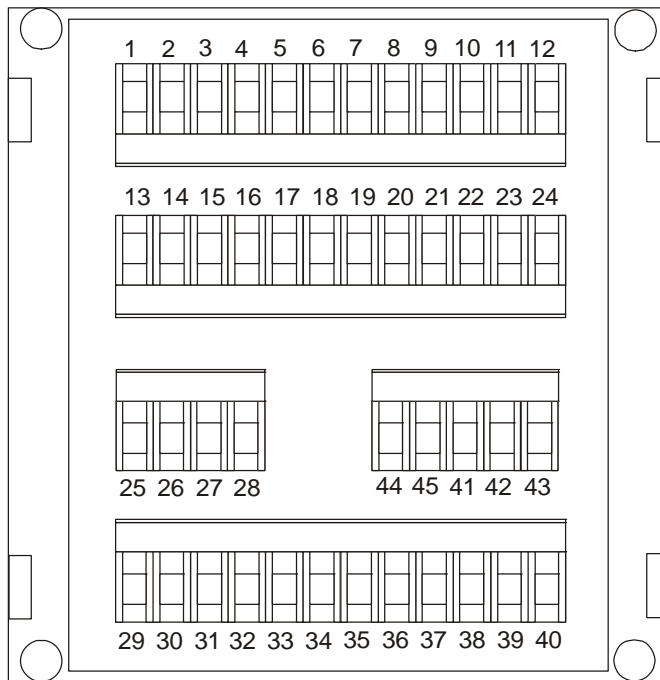

DESCRIPTION FRONT PANEL – OPERATORS

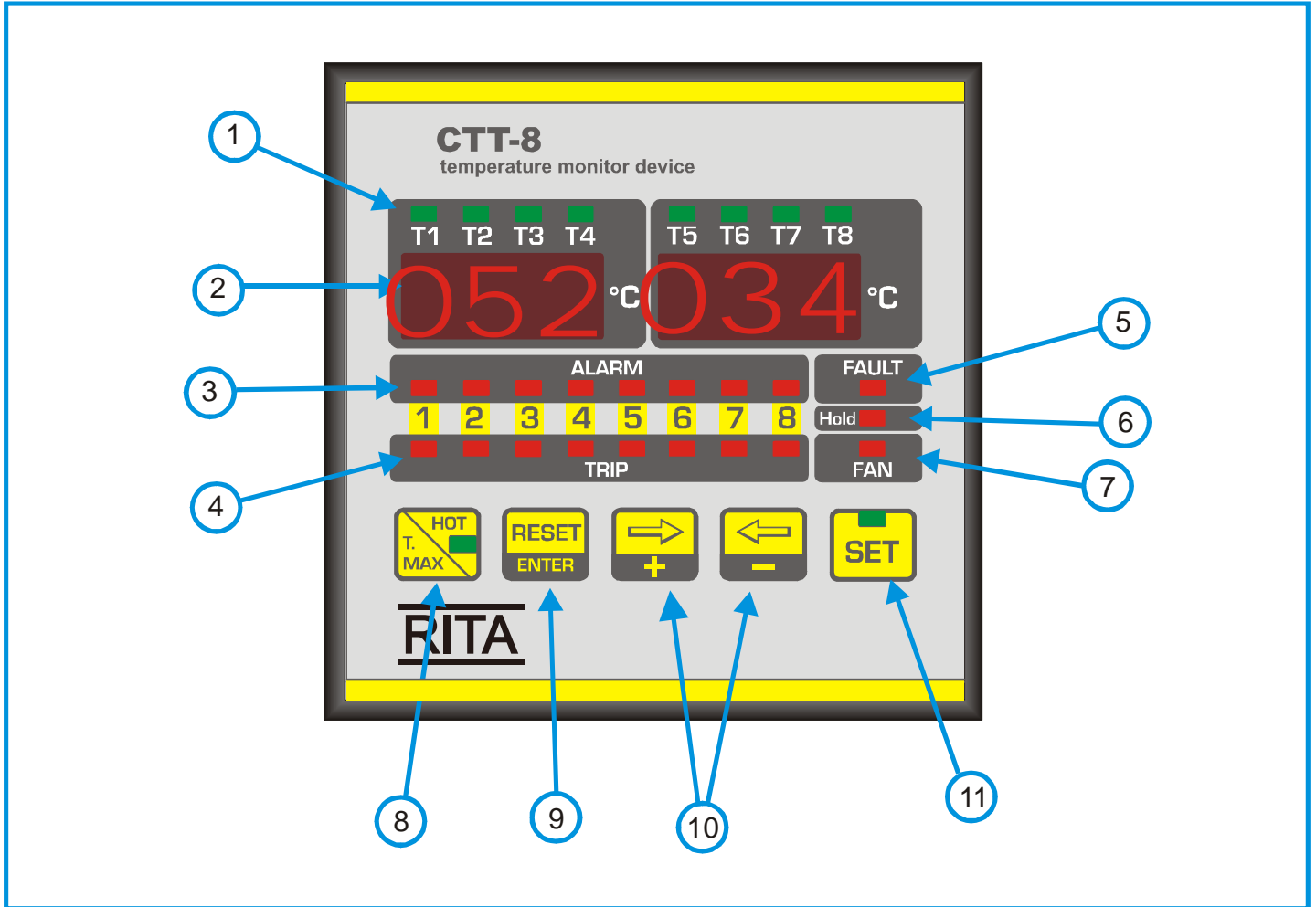

LEGEND:

1. LEDs **T1-T2-T3-T4-T5-T6-T7-T8** of indication measure channel displayed
2. displays for the visualization of the values of temperature and settings
3. LEDs **ALARM** for the visualization of the status of alarm of the measure channels
4. LEDs **TRIP** for the visualization of the status of trip (2nd level of alarm) of the measure channels
5. LED **FAULT** of indication failure device or thermometric probes
6. LED **HOLD** of indication function of manual reset activated
7. LED **FAN** of indication activation output of ventilation
8. push - button **HOT / T. MAX** for selection visualization measure channel with higher temperature (with LED indication activated) and visualization maximum temperatures achieve
9. push - button **ENTER / RESET** to confirm set of programming and manual reset alarm intervention
10. push - buttons **⇒+ / ←-** for selection measure of channel displayed and for changing parameter of programming
11. push - button **SET** with LED of status to accede at the programming of the instrument setting

PROGRAMMING OF THE DEVICE

When the device is switched on, on the display will flash the index of the internal software: later the device starts to display the temperature read on the measure input.

To enter in the programming phase press the button SET for some second up to light the relative LED of signalling SET. The settings are indicated in sequence like showed after; to go out of the programming phase without to modify the values it's necessary to press SET without to confirm with the ENTER key the data modified.

To modify the value or the status it's necessary to use \Leftarrow and \Rightarrow keys and the ENTER key to store the modification. The pressure of the ENTER key move automatically the programming at the successive function or value.

Selection of the HOLD function

This is the first function to set in the menu programming (SET): in this phase of programming the HOLD led switch on. The Hold function allows to store the alarm condition that can be rearmed only manually with the RESET button when the temperature are lower than the threshold set.

If this function is disabled it's possible to rearm the ALARM with the RESET button even if the temperature is higher than the threshold set, while the value of temperature come back under the threshold set the alarm will be automatically deleted.

To set the Hold function it's necessary to use the \Leftarrow and \Rightarrow keys:

OFF function disabled

ON function enabled

Press the ENTER key to confirm the operation.

Set HOLD modality	T1-T2-T3-T4	T5-T6-T7-T8
HOLD mode disabled	HLD	Of f
HOLD mode enabled	HI D	ON

Selection of the threshold of switch on and switch off ventilation

To program the threshold of enable and disable ventilation it's necessary to select the modality of functioning ventilation.

Selection threshold of disable ventilation

The FAN led on, with fixed light indicates this phase of programming.

With \Leftarrow and \Rightarrow keys to select the value of temperature indicated on display.

Interval of programming: from -25°C up to the threshold of enable ventilation -1°C.

Confirm with ENTER.

Selection threshold of enable ventilation:

The fan led on, with flashing light indicates this phase of programming.

With \Leftarrow and \Rightarrow keys to select the value of temperature indicated on display.

Interval of programming: from disabling threshold +1°C up to 200 °C.

Confirm with ENTER.

Selection of the alarm and tripped threshold

The set phase of the alarm thresholds start from the programming for the measure channel number 1.

The ALARM led on indicates the programming of the alarm:

With \Leftarrow and \Rightarrow keys to select the value of temperature

Interval of programming: from -25°C up to the tripping threshold -1°C

Confirm with ENTER.

The TRIP led on indicates the programming phase of the tripping threshold.

With \Leftarrow and \Rightarrow keys to select the value of temperature

Interval of programming: from alarm threshold + 1°C up to 200°C.

Confirm with ENTER.

Selection of address network identification for the communication of the serial port (MODBUS-RTU protocol)

Note: This setting is not significant for the models without the serial interface installed.

This phase is indicated on displays where there is value in definition on displays T1-T2-T3-T4,

ID on displays T5-T6-T7-T8

With \Leftarrow and \Rightarrow keys to select the number choice.

The range for value accepted is from 1 to 247.

Confirm with ENTER.

Set	T1-T2-T3-T4	T5-T6-T7-T8
Set address network	001	ID

Selection of the baud rate

Note: This setting is not significant for the models without the serial interface installed.

This phase is indicated on displays where there is

BDR on displays T1-T2-T3-T4,

and the value to set on displays T5-T6-T7-T8.

With \Leftarrow and \Rightarrow keys to select the baud rate.

It's possible to set the following values: 2,4 - 4,8 - 9,6 - 19,2 kbps.

Confirm with ENTER.

Set	T1-T2-T3-T4	T5-T6-T7-T8
Baud rate: 19200	BDR	19.2
Baud rate: 9600	BDR	9.6
Baud rate: 4800	BDR	4.8
Baud rate: 2400	BDR	2.4

Selection data bit, parity and stop bit

Note: This setting is not significant for the models without the serial interface installed.

This phase is indicated on displays where there is
The type of parity on displays T1-T2-T3-T4;
number of data bit and stop bit on display T5-T6-T7-T8.
With \leftarrow and \rightarrow keys to select the set choice.
Confirm with ENTER.

Set	T1-T2-T3-T4	T5-T6-T7-T8
No parity / 8 data bit – 1stop bit	NO	8-1
No parity / 8 data bit – 2stop bit	NO	8-2
Odd parity / 8 data bit – 1stop bit	ODD	8-1
Even parity / 8 data bit – 1stop bit	EVE	8-1

Selection of the linked channel with the analogue output

Note: This setting is not significant for the models without the analogue output installed.

This phase is indicated on displays where there is
AN on displays T1-T2-T3-T4,
the measure of the linked channel on displays T5-T6-T7-T8 (CH 1/2/3/4/5/6/7/8 for measure channel 1 / 2 / 3 / 4 / 5 / 6 / 7 / 8, a1 l to link the output on the measure channel with the highest temperature).

With \leftarrow and \rightarrow keys to select the set choice.
Confirm with ENTER.

Linked channel	T1-T2-T3-T4	T5-T6-T7-T8
Channel with the highest temperature	AN	a1 l
Measure channel CH 1	AN	ch1
Measure channel CH 2	AN	ch2
Measure channel CH 3	AN	ch3
Measure channel CH 4	AN	Ch4
Measure channel CH 5	AN	Ch5
Measure channel CH 6	AN	Ch6
Measure channel CH 7	AN	Ch7
Measure channel CH 8	AN	Ch8

Configuration output signal

Note: This setting is not significant for the models without the analogue output installed.

In this phase it's possible to define the type of signal of analogue output as $0 \div 20$ mA or $4 \div 20$ mA.

This phase is indicated on displays where there is
aNO -2O to set the output as $0 \div 20$ mA or
(0 mA = -30° ; 20 mA = 200°)
aN4 -2O to set the output as $4 \div 20$ mA.
(4 mA = -30° ; 20 mA = 200°)

Signal configuration	T1-T2-T3-T4	T5-T6-T7-T8
Output proportionally $0 - 20$ mA	AN 0	-20
Output proportionally $4 - 20$ mA	AN 4	-20

With \leftarrow and \rightarrow keys to select the options.
Confirm with ENTER.

Note: The maximum load for analogue output is 400 ohm.

Configuration diagnostic probes

This function allows to enable or to disable the control on the probes.

The function control the variation of the temperature in a defined time. There is a problem if this variation is higher than a set value.

It's necessary to set the maximum variation temperature:

FDC: min 5°C – max 30°C

and after the time in which to do the control:

FDC: min $10''$ – max $90''$ (period in seconds)

The $\Rightarrow+$ key is used to increase the values while the $\leftarrow-$ key to decrease.

Confirm with ENTER.

Setting FDC modality	T1-T2-T3-T4	T5-T6-T7-T8
FDC mode disabled	FDC	Off
FDC mode enabled	FDC	ON

Temperature configuration FDC	T1-T2-T3-T4	T5-T6-T7-T8
Min $^\circ\text{C}$	FDC	5°
Max $^\circ\text{C}$	FDC	30°

Period configuration FDC	T1-T2-T3-T4	T5-T6-T7-T8
Min in seconds	FDC	$10''$
Max in seconds	FDC	$90''$

The exit of the programming phase

Press the SET key or wait for about 8 seconds without to press any key to come out of the programming phase.

MODALITY OF TRIPPING AND RESTORE

Alarm

At the overcoming of 1°C of the value of threshold set on the input, after 5 seconds, on the channel where the threshold value has been exceeded, the ALARM relay is energized and the ALARM led is on. The restore from the alarm condition with relay de-energized and the relative led off, happen when the temperature go down of 2°C respect at the threshold value set.

Trip

At the overcoming of 1°C of the value of threshold set on the input, after 5 seconds, on the channel where the threshold value has been exceeded, the TRIP relay is energized and the TRIP led is on. The restore from the alarm condition with relay de-energized and the relative led off, happen when the temperature descend of 2°C respect at the threshold value set.

To silence alarm

If the Hold function is disabled it's possible to silence the alarm condition that there is on the measure input.

When there is an alarm condition the ALARM relay and the "ALARM" optical signalling are enabled.

Pressing the Reset button the relay is de-energized while the optical signalling of the alarm condition become flash.

If the temperature increase up to reach the TRIP temperature minus 1°C , the relay and the optical signalling are enabled another time. If after the reset, the temperature go down under the threshold value set, the flashing optical signalling will be automatically deleted.

DIAGNOSTIC

The device is provided of the thermal probes diagnostic function.

The condition controlled on the measure input are:

Probe Pt100 interrupted signalling on the display of the message OPE (open)

Probe in short circuit signalling on the display of the message SHR (short circuit)

Fast variation of temperature signalling on the display of the message FDC (fast changing temperature)

When the device switch on the auto-diagnostic FAULT relay commute and it remain in the status of energized until one of the conditions above described appears, for a failure of the device or if the power supply is absent.

The anomaly condition is signalled also by the FAULT led on.

Every time that a probe of a channel is out of order because it's interrupted (OPE) or in short circuit (SHR) or the delta of temperature is too much elevated (FDC), the led of the corresponding channel flash until stopping of the anomaly. The alarm of interrupted probe (SHR) or open probe (OPE) will be reset automatically while the alarm for the delta of temperature (FDC) disappears only pressing the ENTER key, and to keep it pressed, to press the $\Rightarrow+$ key at least 5 seconds.

The status of the contact of the relay (all available with exchange contact) is showed in the following table:

RELAY	DISABLE STATUS	ENABLE STATUS	UNPOWERED STATUS
ALARM	ALARM OFF: CLOSED 29-30	ALARM ON: CLOSED 29-31	CLOSED 29-30
TRIP	TRIP OFF: CLOSED 32-33	TRIP ON: CLOSED 32-34	CLOSED 32-33
FAN	FAN OFF: CLOSED 35-36	FAN ON: CLOSED 35-37	CLOSED 35-36
FAULT	FAULT OFF: CLOSED 38-40	FAULT ON: CLOSED 38-39	CLOSED 38-39

VISUALIZATION OF THE MAXIMUM MEASURED VALUE OF TEMPERATURE

Pressing the **Tmax** key on displays appear, in modality flashing, the maximum measured value of temperature. To pass from the visualization of the maximum temperature T1-T5 to T2-T6, T3-T7 and T4-T8 to use \Leftarrow and \Rightarrow keys. After an interval of about 8 seconds without to press any key the device come back to display the value of measured temperature. To reset the value of the maximum temperature it's necessary to go in the visualization maximum values and after to press at the same time Tmax and \Leftarrow .

VISUALIZATION OF THE CHANNELS WITH THE HIGHER TEMPERATURE

Press the **HOT** key for same second up to switch on the HOT led.

On the display T1-T2-T3-T4 will appear the temperature of the measure channel hotter between the inputs 1, 2, 3, and 4.

On the display T5-T6-T7-T8 will appear the temperature of the measure channel hotter between the inputs 5, 6, 7 and 8.

To come back in the standard modality of measure visualization press the HOT key for some second up to switch off the relative led of signalling.

TEST OF THE LIGHT SIGNALLING

Press at the same time \Leftarrow and \Rightarrow keys: all of the light signalling will start to flash for some seconds.

VISUALIZATION OF THE MEASURED TEMPERATURE

On the display on the left of the front panel appears the temperature of the channels T1 T2 T3 T4 in the range $-30^{\circ}\text{C} \div +220^{\circ}\text{C}$.

On the display on the right on the front panel appears the temperature of the channel T5 T6 T7 T8 in the range $-30^{\circ}\text{C} \div +220^{\circ}\text{C}$.

Use \Leftarrow and \Rightarrow keys to change the measure channels displayed.

EXCLUSION OF THE PROBE INPUTS NOT USED

If one or more inputs are not used, it's need to connect a resistance of value included between 100 and 120 ohm, 0.25W.

In the figure is showed the connection to disable the input Ch1. The same connection can be used also for the other inputs.

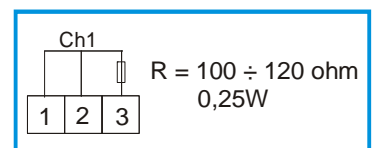

TECHNICAL FEATURES

Auxiliary power supply	20÷250Vca/cc or 115-230-400 Vca 50-60Hz ±15%
Maximum consumption	4 VA
Measure inputs	8 inputs by RTD Pt100 (max wire resistance 20 ohm)
Interval of measure	-30°C ÷ +200 °C / precision ± 2°C
Interval of visualization	-30°C ÷ +220°C
Tripped delay - hysteresis	5 seconds – 2 °C
Measure visualization	2 displays with led 7 segments, 3 digit
Outputs	4 relay NO-C-NC, 5 A resistive load
Output functions	alarm, trip, fan, auto-diagnostic (fault)
Functions programmable	ALARM, TRIP, HOLD, FAN, T.MAX, HOT
Connection	Extractible terminal with screws, section wires max 2,5 mm ²
Insulation	2500 Vrms 50 hz per 60 sec :U aux - input Pt100 / U aux - relay outputs / inputs Pt100 - relay outputs
Protection degree	IP52 front panel (IP65 with optional protection cover), IP20 rear panel, as CEI-EN 60529
Dimensions – enclosure	Flash mounting DIN 96x96mm, depth 120mm / Enclosure thermoplastic self-extinguishing as UL94 V0
Working temperature	-10°C ÷ +60°C, humidity max 95%
Storing temperature	-25°C ÷ +70°C
Standards	EMC: CEI-EN 50081-2 CEI-EN50082-2 security CEI 41.1 CEI-EN 60255-

DIMENSIONS

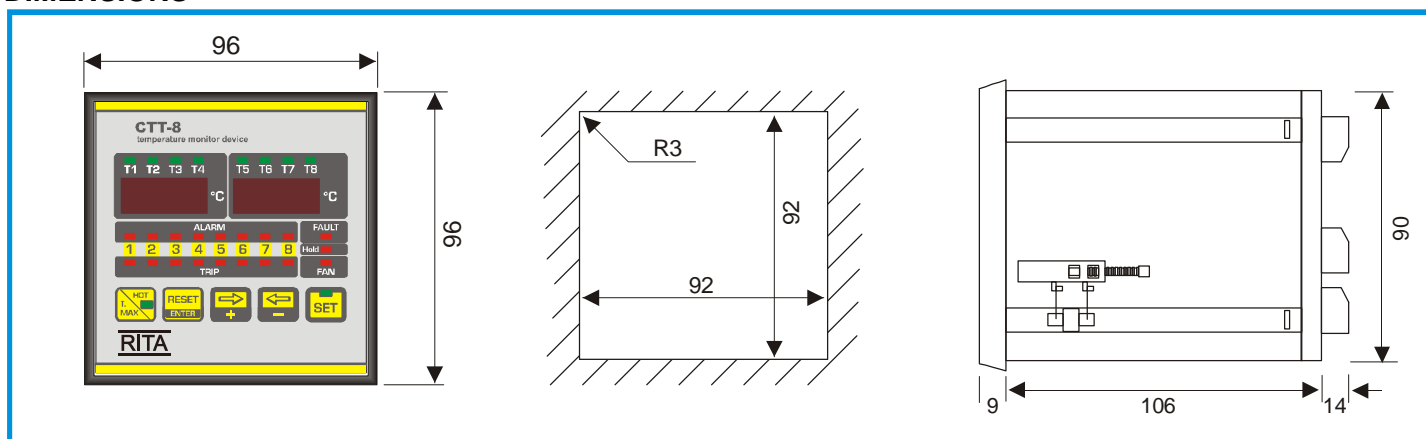

Contact the technical assistance or refer at specific document for application don't described in this manual.

RITA RITA TECHNICAL CO., LTD.

6F No.68 Xing Ai Road, Taipei 114, Taiwan, R.O.C

TEL: +886-2-8791-8588

FAX: +886-2-8792-6911

E-mail: toyotech@ms37.hinet.net