

Catalogue

2013

Medium Voltage Distribution

## SF Circuit Breaker

 Merlin Gerin

### Cradle for SF1

Up to 24kV, 1250A, 25kA

**Ready to install withdrawable circuit breaker in all type of cubicle for a complete safe to operate.**

#### Withdrawable SF1 circuit breaker

- SF6 breaking technique
- 3 separated poles
- Electrical RI operation mechanism including:
  - electrical/manual “closing” & “opening” system;
  - electrical/manual spring charging device;
  - operations counter.
- Parallel-pull-out truck fitted with:
  - an earthing clip;
  - a mechanical system securing the unit being withdrawn only possible in “open” state;
  - a mechanical system securing the unit operations (closing/opening) only possible in “service” or “test” position.
  - a mechanical system locking all the moving parts when circuit breaker is in “connected” position.
  - control mechanism status indicator (charged/discharged) closing button and opening button (manual operation) breaker ON/OFF indicator
- Fixed portion fitted with:
  - bushings: electrical insulating and built-in contacts;
  - metal safety shutters: automatically blank off the fixed contacts and manually be pad-lockable in “test” position;
  - a guide rail at the bottom.
  - an earthing pad: to maintain the continuity to earth while the unit being inserted.
  - test and service position switch by option.
  - a pressure switch for the high performance versions.

The LV plug of the unit, which is used to connect the auxiliary circuits, cannot be accessed in “service” position but in “test” position.



### A complete safe to operate

- Bushings with metallic shutters
- Operating and testing positions
- Interlocking and padlocking
- Conformity standard:
  - IEC 60694:
    - common specifications for high voltage switchgear
  - IEC 62271-100:
    - high voltage alternating current circuit breakers

**Schneider**  
Electric

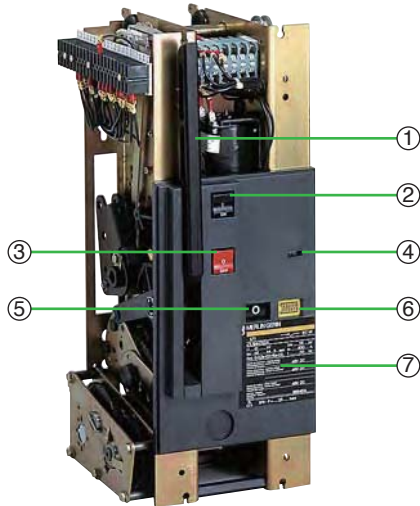

- ① charging lever
- ② closing pushbutton
- ③ opening pushbutton
- ④ operation counter
- ⑤ mechanical indicator for “open” or “close” status of the GCB
- ⑥ mechanical indicator for “charged” or “uncharged” status of charging mechanism
- ⑦ nameplate: indicating model type, specifications and other related information

**Breaking principle: puffer type**

SF circuit breakers use the puffer principle with SF6 gas, 3 poles integrated in a “sealed pressure system” type insulating enclosure.

This method cools and extinguishes the electrical arc as it passes through zero current by puffing a gas compressed by a piston attached to the moving contact. The gas is channeled by an insulating nozzle towards the tubular arcing contacts that are used as an exhaust.

This breaking technique is used for high-performance breaking applications (40.5 kV-31.5 kA) and has been used for the past 37 years.

The operating sequence in a puffer-type breaking chamber with the moving part actuated by a control mechanism is as follows:

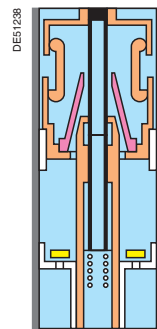

■ the circuit breaker is closed

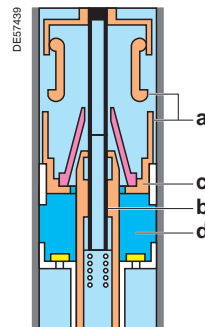

■ following an opening order the main contacts separate (a) and the current is directed into the breaking circuit (b). When the main contacts start to open the piston (c) slightly compresses the SF6 gas in the compression chamber (d)

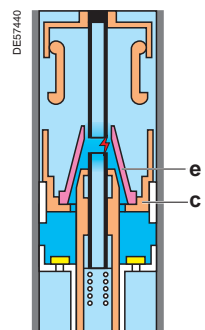

■ an electrical arc appears on separation of the arcing contacts. The piston (c) continues its travel downwards. A small quantity of the gas channeled by the insulating nozzle (e) is injected towards the arc. For low current breaking, the arc is cooled by forced ventilation. However, for high currents the thermal expansion moves the hot gases towards cooler parts in the breaking unit.

The distance between arcing contacts becomes sufficient to allow breaking of the current when it passes through zero due to the dielectric properties of the SF6 gas

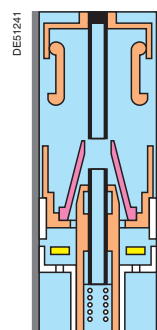

■ the moving parts finish their movement and injection of cold gas continues until the contacts are fully open. The circuit breaker is open.

| Electrical characteristics according to IEC 62271-100 |                                |                                |       |            |      |    |      |
|---|--------------------------------|--------------------------------|-------|------------|------|----|------|
| Rated voltage   | Ur                             | kV 50/60 Hz                    |       | 24         |      |    |      |
| Insulation voltage                                    |                                |                                |       |            |      |    |      |
| - power frequency withstand                           | Ud                             | kV 50/60 Hz 1min               |       | 50         |      |    |      |
| - lightning impulse withstand                         | Up                             | kV peak                        |       | 125        |      |    |      |
| Rated current   | Ir                             | A                              | 400   | -          | -    | -  | -    |
|   |                                |                                | 630   | -          | ■    | -  | ■*   |
|   |                                |                                | 1250  | -          | -    | -  | ■    |
| Short circuit current                                 | Isc                            | kA                             |       | 12.5       | 16   | 20 | 25   |
| Short time withstand current                          | I <sub>k</sub> /t <sub>k</sub> | kA/3 s                         |       | 12.5       | 16   | 20 | 25   |
| Short-circuit making current                          | I <sub>p</sub>                 | kA peak                        | 50 Hz | 31.3       | 40   | 50 | 62.5 |
|   |                                |                                | 60 Hz | 32.5       | 41.6 | 52 | 65   |
| Rated switching sequence                              |                                | O-3 min-CO-3 min-CO            |       | ■          |      |    |      |
|   |                                | O-0.3 s-CO-3 min-CO            |       | ■          |      |    |      |
|   |                                | O-0.3 s-CO-15 s-CO             |       | ■          |      |    |      |
| Phase to phase  |                                | mm                             | 220   | -          | -    | -  | -    |
|   |                                |                                | 250   | ■          | ■    | ■  | ■    |
|   |                                |                                | 280   | -          | -    | -  | -    |
|   |                                |                                | 350   | -          | -    | -  | -    |
|   |                                |                                | 380   | -          | -    | -  | -    |
| Operating mechanism                                   |                                | A1 lateral (*)                 |       | ■          | ■    | ■  | ■    |
|   |                                | B1 lateral (*)                 |       | ■          | ■    | ■  |      |
|   |                                | C1 frontal (*)                 |       | ■          | ■    | ■  |      |
|   |                                | For SM6 switchgear             |       | ■          | ■    | ■  | -    |
| Operating times (main contact)                        |                                | Opening (ms)                   |       | < 50       |      |    |      |
|   |                                | Breaking (ms)                  |       | < 60       |      |    |      |
|   |                                | Closing (ms)                   |       | < 65       |      |    |      |
| Service temperature                                   | T                              | °C                             |       | -25 to +40 |      |    |      |
| Mechanical endurance                                  |                                | Class                          |       | M2         |      |    |      |
|   |                                | Number of switching operations |       | 10,000     |      |    |      |
| Electrical endurance                                  |                                | Class                          |       | E2         |      |    |      |
| Capacitive current breaking capacity                  |                                | Class                          |       | C2         |      |    |      |

■ Available  
- Not available  
\* Supplied with 1250A breaker

### ■ Dimensions

H: height ..... 1223mm  
W: width ..... 920mm  
D: depth ..... 1189.5mm  
Distance between phases..... 250mm

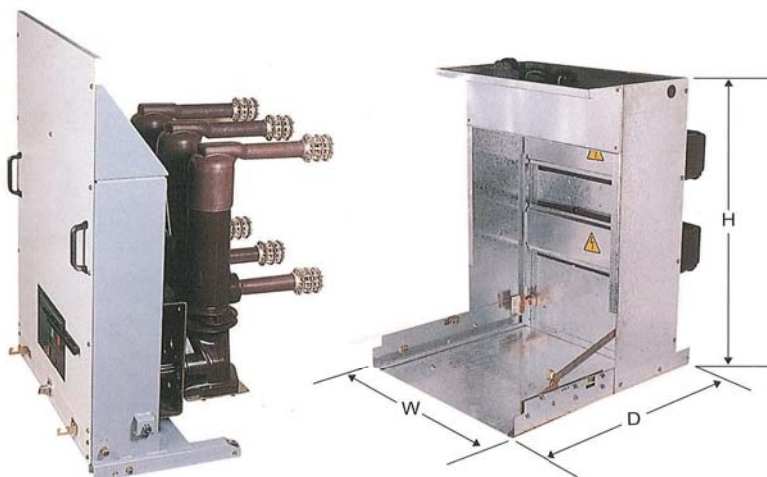

### Specific applications

#### Switching and protection of capacitor banks

SF range circuit breakers are particularly well suited to switching and protection of capacitor banks; they are classed C2 according to standard IEC 62271-100. Tests carried out according to the standard for breaking at 400 A with making and breaking cycles in case of a capacitor bank with a making current of 20 kA. Additional tests have been carried out: please consult us.

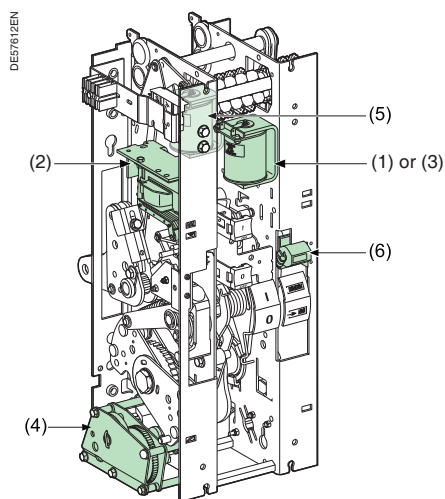

Operating mechanism

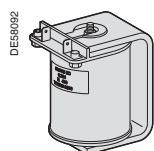

Shunt opening release (1)

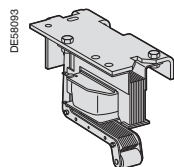

Undervoltage release (2)

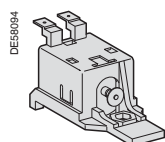

Low energy release (3)

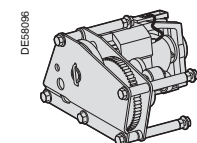

Electrical motor with gearing (4)

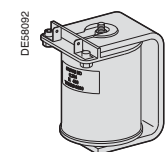

Shunt closing release (5)

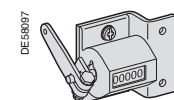

Operation counter (6)

### Shunt opening release (YO1 and YO2)

Energizing this unit causes instant opening of the circuit breaker.

| Characteristics |      |         |                          |
|-----------------|------|---------|--------------------------|
| Power supply    | V AC | 50/60Hz | 48V, 110V, 220V          |
|                 | V DC |         | 24V, 48V, 110/125V, 220V |
| Threshold       | V AC |         | 0.85 to 1.1 Ur           |
|                 | V DC |         | 0.7 to 1.1 Ur            |
| Consumption     | V AC |         | 160 VA                   |
|                 | V DC |         | 50 W                     |

### Undervoltage release (YM)

This release unit causes the systematic opening of the circuit breaker when its supply voltage drops below a value less than 35% of the rated voltage, even if this drop is slow and gradual. It can open the circuit breaker between 35% and 70% of its rated voltage. If the release unit is not supplied power, manual or electrical closing of the circuit breaker is impossible. Closing of the circuit breaker is compulsory when the supply voltage of the release unit reaches 85% of its rated voltage.

| Characteristics |            |         |                          |
|-----------------|------------|---------|--------------------------|
| Power supply    | V AC       | 50/60Hz | 48V, 110V, 220V          |
|                 | V DC       |         | 24V, 48V, 110/125V, 220V |
| Threshold       | Opening    |         | 0.35 to 0.7 Ur           |
|                 | Closing    |         | 0.85 Ur                  |
| Consumption     | Triggering | V AC    | 400 VA                   |
|                 |            | V DC    | 100 W                    |
|                 | Latched    | V AC    | 100 VA                   |
|                 |            | V DC    | 10 W                     |

### Low energy release (Mitop)

This specific release unit comprises a low consumption unit and is specially used for Sepam 100LA self-powered relays.

| Characteristics |                 |
|-----------------|-----------------|
| Power supply    | Direct current  |
| Threshold       | 0.6 A < I < 3 A |

Any tripping due to the Mitop release unit is momentarily indicated by an SDE type changeover contact (option).

### Electrical motor with gearing (M)

The electrical motor carries out the automatic rearming of the stored energy unit as soon as the circuit breaker is closed. This allows the instant reclosing of the device after opening. The arming lever is only used as a backup operating mechanism in the case of the absence of the auxiliary power supply.

The M3 contact indicates the end of arming operations.

| Characteristics |                      |                     |
|-----------------|----------------------|---------------------|
| Power supply    | 48...60V AC/V DC,    | 110...127 V AC/V DC |
|                 | 220...250 V AC/V DC, | 24...32 V DC        |
| Threshold       | V AC/V DC            | 0.85 to 1.1 Ur      |
| Consumption     | V AC                 | 380 VA              |
|                 | V DC                 | 380 W               |

### Shunt closing release (YF)

This release allows the remote closing of the circuit breaker when the operating mechanism is armed.

| Characteristics |      |         |                          |
|-----------------|------|---------|--------------------------|
| Power supply    | V AC | 50/60Hz | 48V, 110V, 220V          |
|                 | V DC |         | 24V, 48V, 110/125V, 220V |
| Threshold       | V AC |         | 0.85 to 1.1 Ur           |
|                 | V DC |         | 0.85 to 1.1 Ur           |
| Consumption     | V AC |         | 160 VA                   |
|                 | V DC |         | 50 W                     |

The shunt closing release is combined with an anti-pumping relay that enables priority to be given to opening in the case of a permanent closing order. This thus avoids the device being caught in an uncontrolled opening-closing cycle.

### Operation counter

The operation counter is visible on the front panel.

It displays the number of switching cycles (CO) that the device has carried out.

DE57491

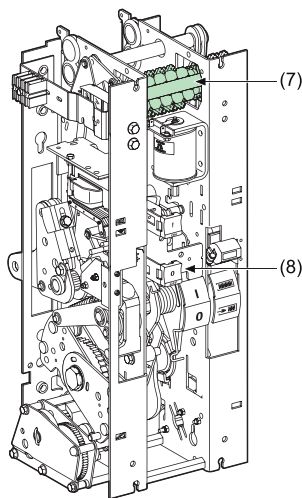

Operating mechanism

DE56098

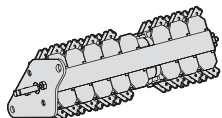

Auxiliary contacts (7)

DE56099

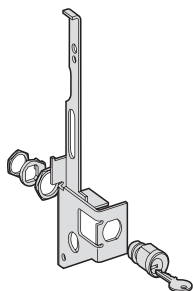

Keylocking kit (8)



Position contact



Condenser tripping device (CTD)

### “Open/closed” auxiliary contacts

The number of contacts available depends on the options chosen on the operating mechanism.

In the basic configuration, the circuit breaker’s operating mechanism comprises a total of:

- 5 normally closed contacts (NC)
- 5 normally open contacts (NO)
- 1 changeover contact (CHG).

The usage procedure for auxiliary contacts is given in the following table:

| Options                          | NC contact | NO contact |
|----------------------------------|------------|------------|
| Shunt opening release (each one) | 0          | 1          |
| Undervoltage release             | 0          | 0          |
| Low energy release (Mitop)       | 0          | 0          |

In order to know the final number of available contacts, you must deduct the total number of contacts included in the circuit breaker (5 NC + 5 NO + 1 CHG), the number of contacts used given in the table above.

**E.g.:** a circuit breaker equipped with a remote control and a shunt trip unit has the following available contacts:

5 NC + 4 NO + 1 CHG.

With a undervoltage release instead of the shunt trip, this circuit breaker would have the following available contacts:

5 NC + 5 NO + 1 CHG.

| Shunt opening release combination |             |                           |                         |              |
|-----------------------------------|-------------|---------------------------|-------------------------|--------------|
|                                   | 1st release | Shunt opening release YO1 | Undervoltage release YM | Mitop        |
| 2nd release                       |             |                           |                         |              |
| Without                           |             | 5NC+4NO+1CHG              | 5NC+5NO+1CHG            | 5NC+5NO+1CHG |
| Shunt opening release YO2         |             | 5NC+3NO+1CHG              | 5NC+4NO+1CHG            | 5NC+4NO+1CHG |
| Undervoltage release YM           |             | 5NC+4NO+1CHG              |                         | 5NC+5NO+1CHG |
| Mitop                             |             | 5NC+4NO+1CHG              | 5NC+5NO+1CHG            |              |

### Locking the circuit breaker in the “open” position

This key-operated device allows the circuit breaker to be locked in the “open” position. The circuit breaker is locked in the open position by blocking the opening push button in the “engaged” position.

Locking is achieved using a Profalux or Ronis captive key type keylock.

### Position Contact

Position contact, activated when circuit-breaker is in the “test” or “service” position.

### Condenser tripping device

Condenser tripping device (CTD, 2000µF) providing DC power for the unit to trip when encountering power failure.

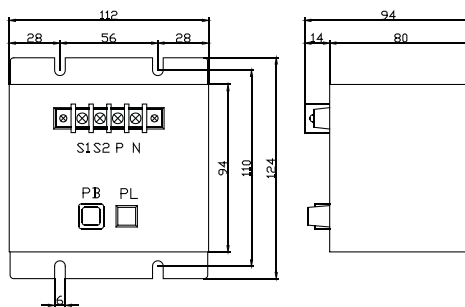

Dimensions & fixing holes of CTD

# Wiring Diagrams

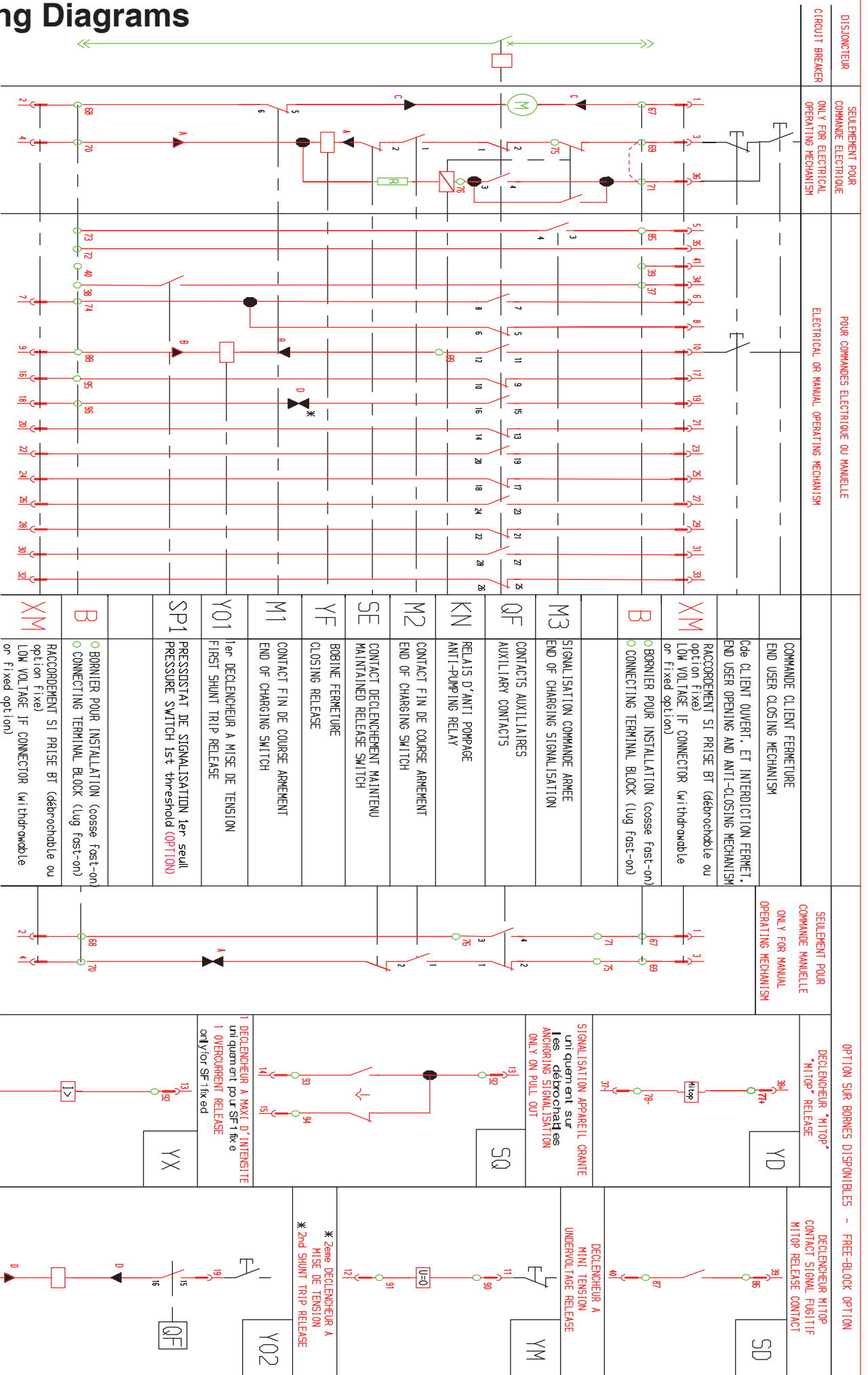

DISJONCTEUR  
SEULEMENT POUR  
COMMANDE ELECTRIQUE  
ONLY FOR ELECTRICAL  
OPERATING MECHANISM

POUR COMMANDES ELECTRIQUE OU MANUELLE  
ELECTRICAL OR MANUAL OPERATING MECHANISM

|            |   |
|------------|---|
|            | COMMANDE CLIENT FERMETURE<br>END USER CLOSING MECHANISM   |
|            | Cde CLIENT OUVERT, ET INTERDICTION FERMETURE,<br>END USER OPENING AND ANTI-CLOSING MECHANISM                          |
|            | RACCORDEMENT SI PRISE BT (détachable ou option fixe)<br>LOW VOLTAGE I/F CONNECTOR (w/ hydro-multiple or fixed option) |
| <b>XM</b>  | BORNIER POUR INSTALLATION (cosse fast-on)<br>CONNECTING TERMINAL BLOCK (lug fast-on)                                  |
| <b>B</b>   | BORNIER POUR INSTALLATION (cosse fast-on)<br>CONNECTING TERMINAL BLOCK (lug fast-on)                                  |
|            | RACCORDEMENT SI PRISE BT (détachable ou option fixe)<br>LOW VOLTAGE I/F CONNECTOR (w/ hydro-multiple or fixed option) |
| <b>XM</b>  | BORNIER POUR INSTALLATION (cosse fast-on)<br>CONNECTING TERMINAL BLOCK (lug fast-on)                                  |
| <b>M3</b>  | SIGNALISATION COMMANDE ARMEE<br>END OF CHARGING SIGNALISATION   |
| <b>QF</b>  | CONTACTS AUXILIAIRES<br>AUXILIARY CONTACTS  |
| <b>KN</b>  | RELAIS D'ANTI POMPAGE<br>ANTI-PUMPING RELAY   |
| <b>M2</b>  | CONTACT FIN DE COURSE ARMEMENT<br>END OF CHARGING SWITCH  |
| <b>SE</b>  | CONTACT DECLENCHEMENT MAINTENU<br>MAINTAINED RELEASE SWITCH   |
| <b>YF</b>  | BOBINE FERMETURE<br>CLOSING RELEASE   |
| <b>M1</b>  | CONTACT FIN DE COURSE ARMEMENT<br>END OF CHARGING SWITCH  |
| <b>Y01</b> | 1er DECLENCHEUR A MISE DE TENSION<br>FIRST SHUNT TRIP RELEASE   |
| <b>SP1</b> | PRESSOSTAT DE SIGNALISATION 1er seuil<br>PRESSURE SWITCH 1st threshold (OPTION)                                       |
|            |   |
| <b>B</b>   | BORNIER POUR INSTALLATION (cosse fast-on)<br>CONNECTING TERMINAL BLOCK (lug fast-on)                                  |
| <b>XM</b>  | RACCORDEMENT SI PRISE BT (détachable ou option fixe)<br>LOW VOLTAGE I/F CONNECTOR (w/ hydro-multiple or fixed option) |

SEULEMENT POUR  
COMMANDE MANUELLE  
ONLY FOR MANUAL  
OPERATING MECHANISM

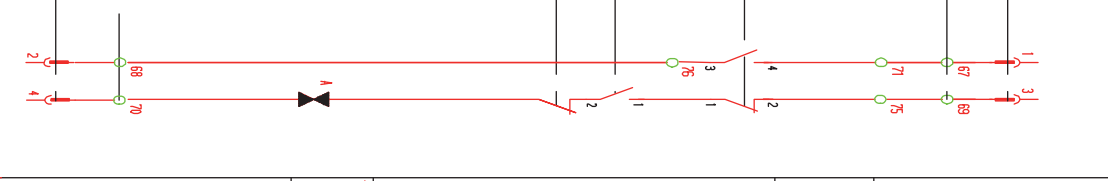

OPTION SUR BORNES DISPONIBLES - FREE-BLOCK OPTION

DECLENCHEUR "MITOP"  
"MITOP" RELEASE

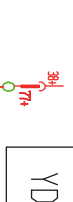

DECLENCHEUR MITOP  
CONTACT SIGNAL FUGITIF  
MITOP RELEASE CONTACT



SIGNALISATION APPAREIL GRANTE  
uniquement sur  
les débranchés  
ANCHORING SIGNALISATION  
ONLY ON PULL OUT

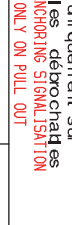

DECLENCHEUR A  
MINI TENSION  
UNDERVOLTAGE RELEASE

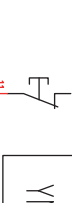

\* 2eme DECLENCHEUR A  
MISE DE TENSION  
\* 2nd SHUNT TRIP RELEASE

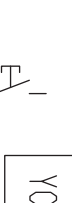

1 DECLENCHEUR A MAXI D'INTENSITE  
uniquement pour Sf-1 fixe  
1 OVERCURRENT RELEASE  
only for Sf-1 fixed



Y02



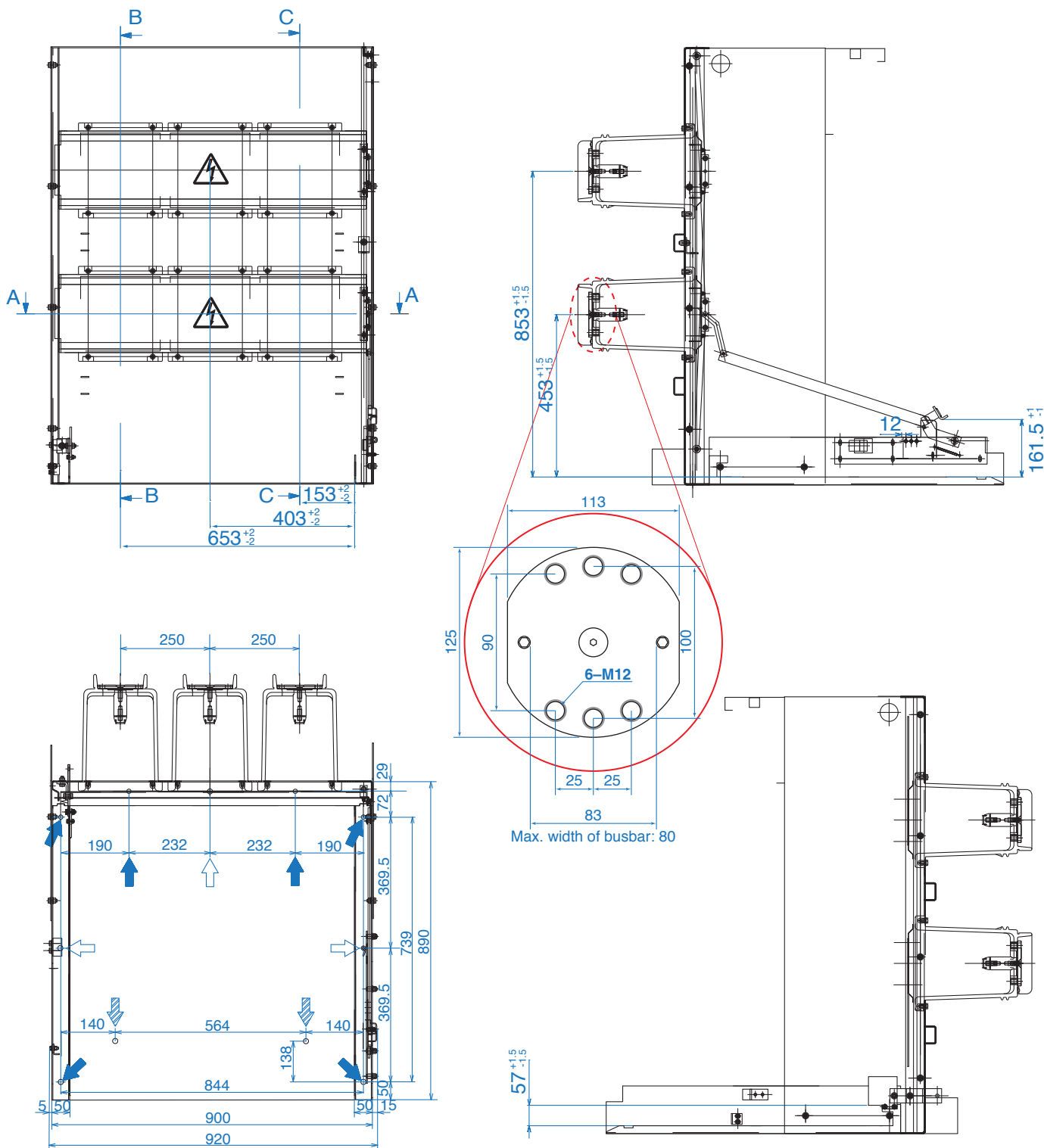

- ➡ 6 X M10 screws for fixing in cubicle (strongly requested)
- ▨ 2 X Ø14 reserved empty holes for CB Rack-IN/OUT help
- ⇨ 3 X Ø12 reserved empty holes for Riveting the bottom plate (strongly requested)

SF1 circuit breaker  
24kV withdrawable

Dimensions  
Breaker

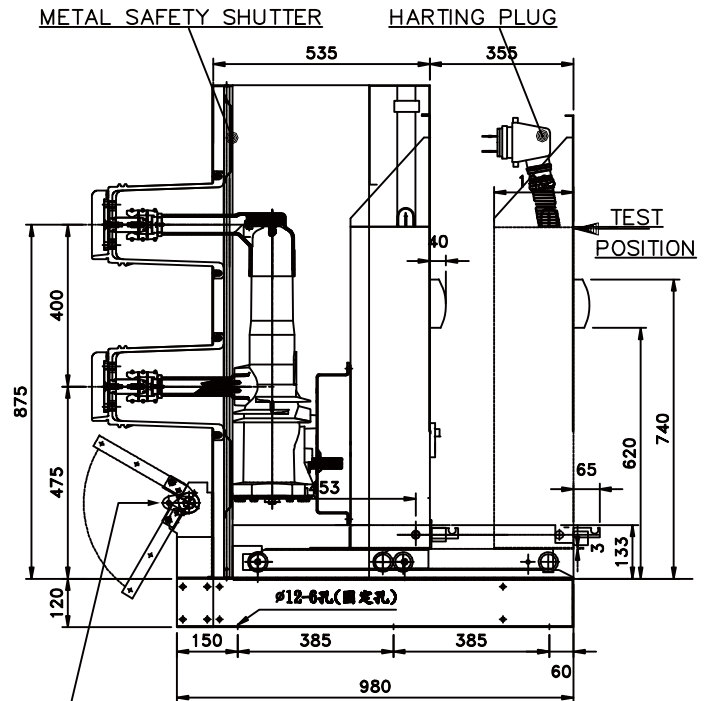
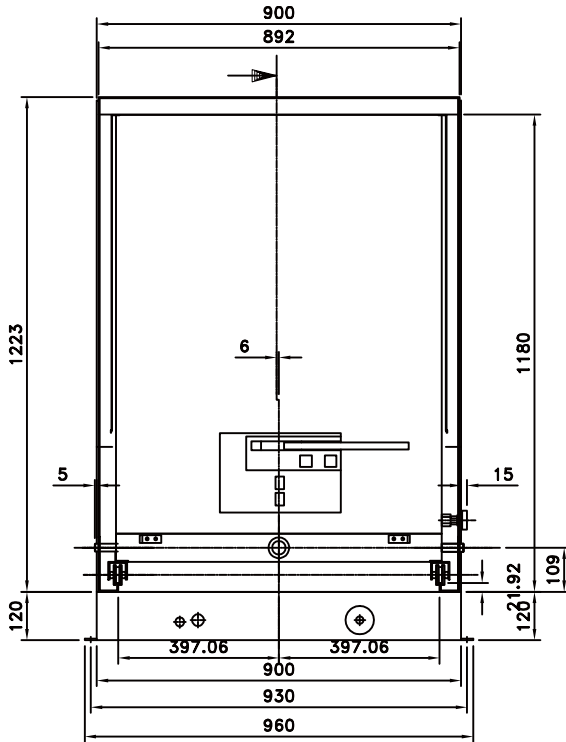

Earthing Switch (optional)

Schneider Electric 施耐德電機授權經銷商

東技企業股份有限公司  
普得企業股份有限公司

總公司: 台北市內湖區行愛路68號6樓

電話: (02)8791-8588

傳真: (02)8791-9588

E-mail: toyotech@ms37.hinet.net

中辦處: (04)2296-9388

高辦處: (07)227-2133

網址: www.toyotech.com.tw