

TOYO

EARTH LEAKAGE RELAY



Introduction

• Earth Fault Protection

The purpose of earth fault protection is to measure the earth leakage current of an electrical installation, or part of an installation and interrupt the supply of power if this current becomes dangerous to life or property. ELR is a range of earth fault relays with separate toroids, a solution offering both flexibility and performance.

• Operation and Use

ELR relays are designed for use on low voltage AC installations. When the residual current detected by the toroid exceeds a certain threshold, referred to as the residual operating current $I_{\Delta n}$, the ELR relay trips the associated circuit breaker via a voltage release on the breaker. The control signal issued by the relay may be instantaneous or delayed.

The choice of the right ELR relay model for a given application depends on the type of protection required:

- additional protection against direct contact;
- protection against indirect contact;
- protection against fire hazards;
- source ground fault protection;
- motor protection.

These five types of protection are covered by standards and correspond to different current thresholds and time delays on the products.

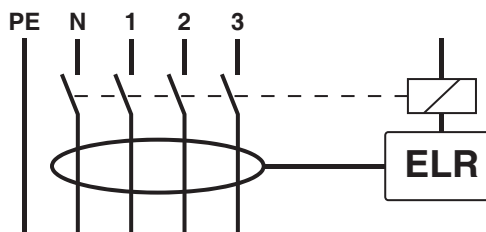

Specification

Type		ELR-96N	ELR-96NA
Auxiliary Supply			
	voltage	AC 110V(94~127V) or AC 220V(184~276V)	
	frequency	50 or 60Hz	
	burden	3VA	
Setting Range			
	sensitivity ($I_{\Delta n}$)	0.03A , 0.05A / 0.1A~1A (0.1A step) / 1A~10A (1A step)	
	time delay	instantaneous / 0.1~3s (0.1s step)	
Output Contact			
	trip contact (1 NO/NC)	activated when leakage trip, manual test trip or ZCT connection error	
	positive safety contact (1 NO/NC)	—	activated when power on and relay function correctly
	50% pre-fault alarm contact (1 NO)	—	activated when measured leakage current exceeded 50% of $I_{\Delta n}$
	rating	5A(NO) / 3A(NC) / 250VAC AC1	
	electrical life	10,000 operations at rated current	
	mechanical life	100,000 operations	
Fault Record		3 latest tripped fault currents	
Remote Test / Reset		—	1 NO dry contact
Indicators			
	pre-fault alarm	red LED indicator (normal blink)	
	time delay	red LED indicator (fast blink)	
	leakage trip	7-segment red LED display (3-digit) and indicator	
	ZCT connection error	7-segment red LED display (3-digit) and indicator	
	real-time leakage current	7-segment red LED display (3-digit)	
	fault record	7-segment red LED display (3-digit)	
Electrical			
	harmonic filter	built-in	
	insulation test	2500V / 1min.	
Mechanical			
	mounting	panel mount (92x92mm)	
	front panel	standard DIN 96x96mm	
	weight	0.58kg (without ZCT)	
Ambiant Temperature		operating: -10 °C~60 °C / storage: -20 °C~70 °C	
Standards		IEC 60755 / IEC 60947-2 Annex M	

Connection Diagrams

ELR 96N

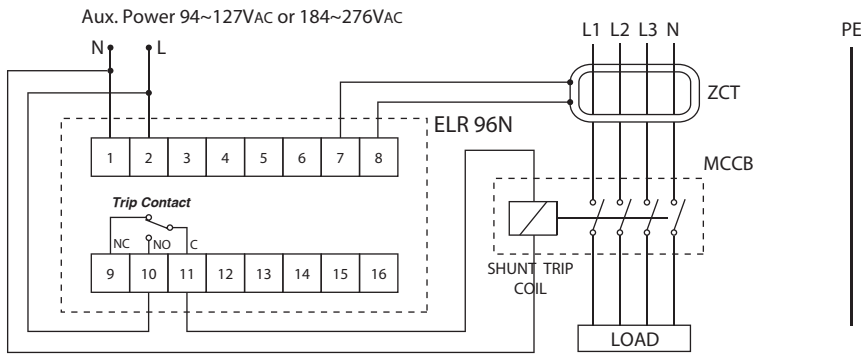

The EARTH must NOT pass through the ZCT

ELR 96NA

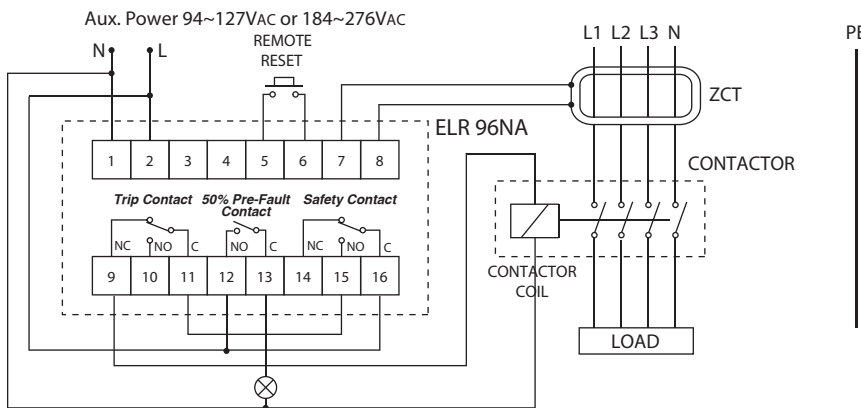

The EARTH must NOT pass through the ZCT

Use with CT

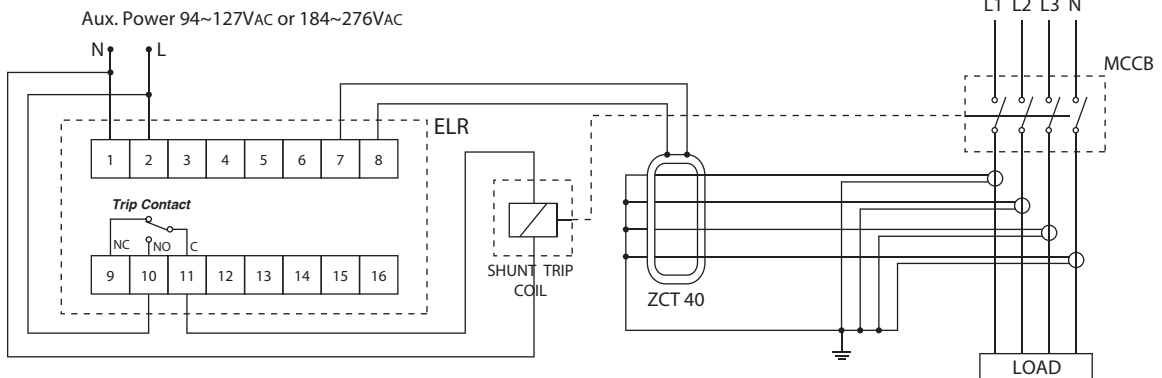

Discrimination

Discrimination consists in:

- Dividing the installation into a number of groups of circuits and protecting each group with an appropriate residual current device.
- Coordinating the upstream and downstream devices such that only the faulty section is shut down.

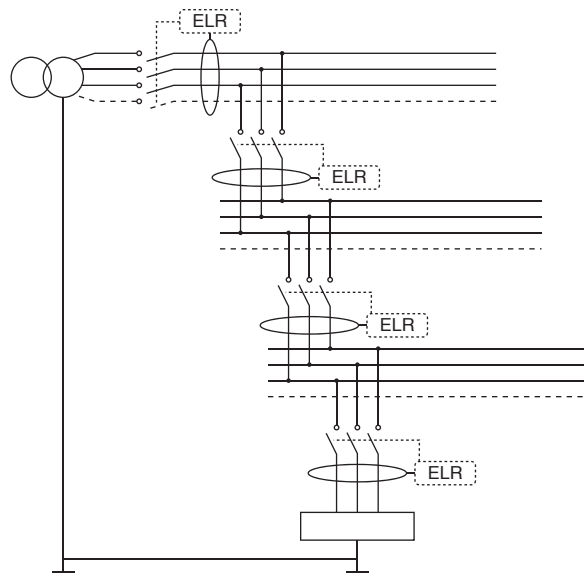

■ Zero Phase Current Transformer

The Zero Phase Current Transformer (ZCT) to be combined with the earth leakage relays consist of a core in magnetic sheet of very good magnetic qualities, which permits to detect fault currents even of very low value.

During installation, inside the zero phase current transformer all phase conductors and eventually the neutral conductor if existing, should pass through. **Attention! The earth conductor (PE) should NOT pass through the ZCT.**

ZCT 40 , 80 , 120 , 210

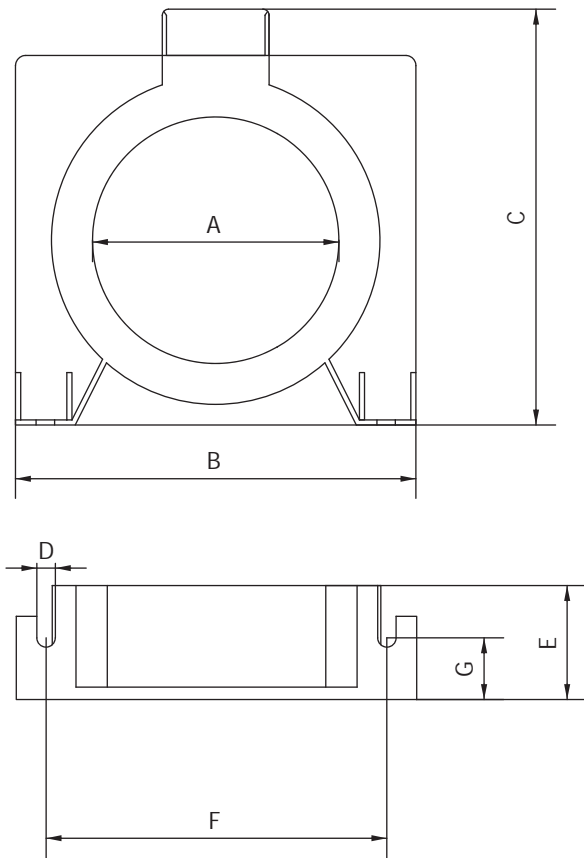

Dimension (mm)	ZCT 40	ZCT 80	ZCT 120	ZCT 210
A	40	80	120	210
B	89	130	180	310
C	94	135	195	311
D	6	6	6	6
E	37	37	37	37
F	75	112	159	292
G	20	20	20	18

■ Ordering Information

Model	Description
ZCT- 40	40mm inner diameter
ZCT- 80	80mm inner diameter
ZCT- 120	120mm inner diameter
ZCT- 210	210mm inner diameter

普得企業股份有限公司

總公司：台北市內湖區行愛路68號6樓
 電話：(02)8791-8588 傳真：(02)8791-9588
 電子郵件：toyotech@ms37.hinet.net
 網址：www.toyotech.com.tw

台中辦事處：台中市文心路四段200號10樓之2
 電話：(04)2296-9388 傳真：(04)2296-9386
 高雄辦事處：高雄市民生一路56號15樓之6
 電話：(07)227-2133 傳真：(07)227-2173